



Fibre Facade Enclosure

LC or SC Adaptors

Application Information

The Fibre Facade Enclosure provides a cost-effective secure solution for installing pre-terminated drop cables in Fibre to the Home (FTTH) applications. The enclosure has been designed to physically separate the feeder cable 250µm fibres, which will be spliced by a skilled technician at the initial install, from the pre-terminated connectorised drop cables which may be installed at a later date and are likely to be completed by a lower skilled installer. It can be mounted aerially or at ground level to deliver up to 12 drop cable customer connections.

Product Description

The Fibre Facade Enclosure is an IP55/IK09 rated enclosure manufactured from UV stabilised polymer. Features are included to provide for mounting on a pole or building facade. The enclosure is supplied in black or grey as standard (other colours are available MOQ dependent) and has provision for a moulded customer logo if required.

The enclosure consists of 3 separate fibre management areas:

- Inbound Cable Management

The lower section of the enclosure has 4 dedicated entry ports with strain relief for incoming feeder cables which can accommodate a mid-span and 2 spur cables. This area provides positive fibre management and loop storage for a maximum of 144 fibres.

- Fibre Splice Management Area

A dedicated splice management tray sits above the fibre storage area and has capacity for up to 12 x 3A heatshrink splices (24 if double stacked), with a maximum splice protector length of 60mm. The tray provides separate fibre management areas for 250µm fibres and 900µm pigtails whilst maintaining 30mm minimum bend radius throughout.

- Drop Cable Management

The drop cable management area consists of a removable upper fibre management tray which presents 12 LC or SC simplex adapters for connection to industry standard pre-terminated drop cables and prevents access to the lower splicing area when in place. Fibre management is provided on the underside of the tray for 900µm pigtails allowing the spare cable to be maintained separately from the 250µm feeder cable fibres. Retaining features allow for a maximum of 3 x 1:4 PLC splitters to be mounted if required. The fibre management maintains a 30mm minimum bend radius throughout with a cross over facility to allow for alternative routing requirements.

The LC/SC simplex adapters on the customer facing side of the tray are angled and spaced to allow for inspection prior to connection. 12 anchor guides are provided for securing the drop cables. Drop cable exit ports use a simple push fit seal to ensure performance in excess of IP55.



Fibre Facade Enclosure (open displaying Drop Cable Management Tray)



Open View of Fibre Facade Enclosure displaying dedicated Splice Management Tray



Closed View of Fibre Facade Enclosure

Features and Benefits:

- Separation of spliced feeder cable from connectorised drop cables
- 12 LC or SC customer connections
- Accommodates 1 x Mid-Span and 2 Spur Cables
- 12 outbound ports
- Positive fibre management (30mm min bend radius)
- IP55 and IK09 rating
- Tamper-proof
- Pole or building facade mounting features
- Low profile
- Range of colours

Technical Data

Dimensions (mm)	D	W	H
	72	154	241
Maximum number customer connections	12 LC APC/PC or 12 SC APC/PC SX adaptors		
Maximum number of splices	24		
Colour	Black or Grey as standard - (MOQ dependent)		
Maximum Fibre Storage	144 Fibres		
Number of Ports	4 inbound ports, 12 outbound ports		
Cable dimensions	Feeder	Drop	
	Maximum 8mm or 16mm	Maximum 8mm	

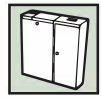

Technical Diagrams

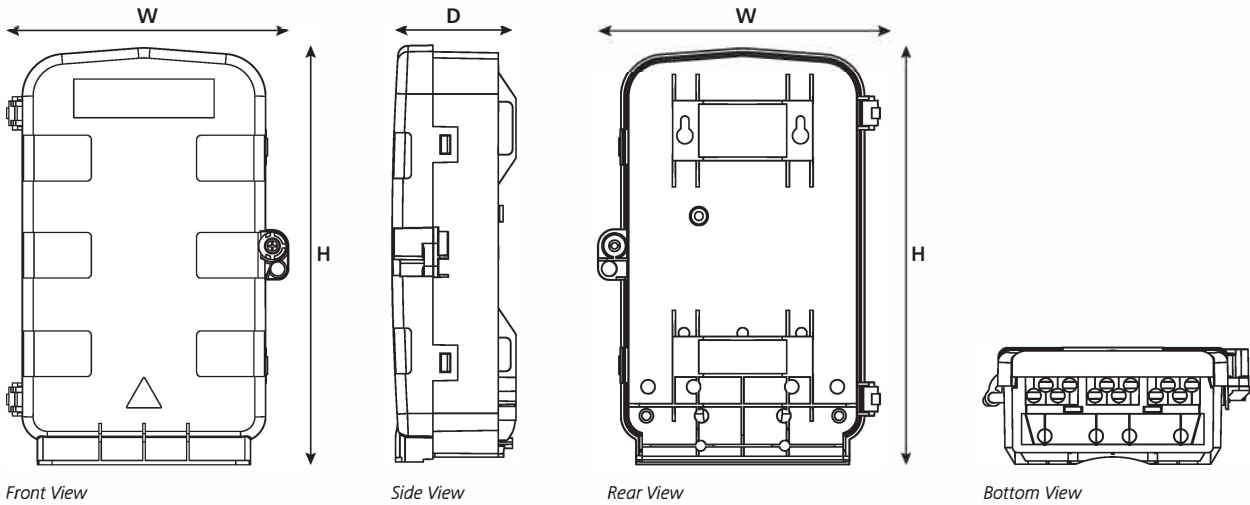

Front View

Side View

Rear View

Bottom View

Accessories

MB-FFE-PM Mounting Bracket

Application Information

The HellermannTyton Fibre Facade Enclosure Pole Mounting Bracket is manufactured from powder coated stainless steel. It's simple design makes it quick and easy to install and provides management for incoming and outgoing cables, in addition to providing storage capacity for excess cables.

Technical Data

Dimensions (mm)	D	W	H
	74	149	329
Material	Powder Coated Stainless Steel		
Colour	Black		

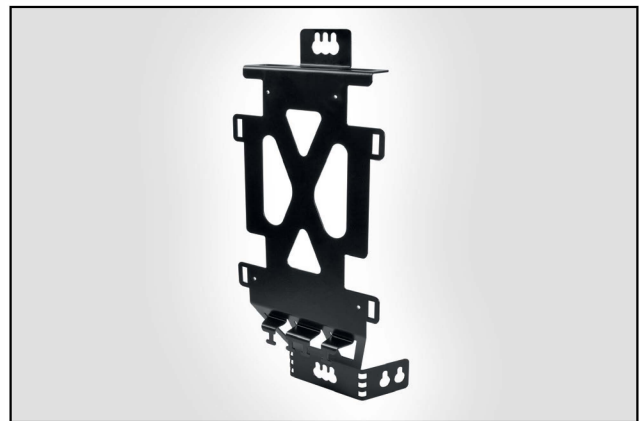

MB-FFE-PM-001 Mounting Bracket

Technical Diagrams

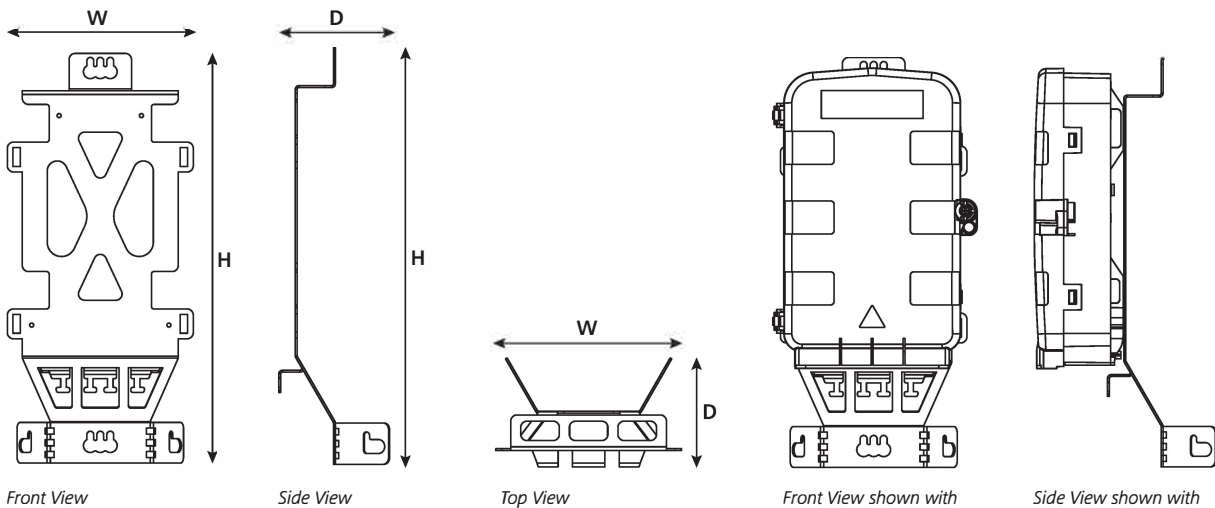

Front View

Side View

Top View

Front View shown with Fibre Facade Enclosure

Side View shown with Fibre Facade Enclosure



Accessories

MB-AFN/FFE-V-BRKT-001 Mounting Bracket

Application Information

The V shaped pole mounting bracket has been designed to provide mounting positions for 2 enclosures and is suitable for use with the Aerial Fibre Node (AFN) and the Fibre Facade Enclosure (FFE).

Anchoring is provided at the base of the bracket for incoming cables and on the left side and the centre for the distribution fibre drops.

The mounting bracket is manufactured from powder coated stainless steel and designed not to exceed the width of the pole top the bracket can pre-loaded with the enclosures and then secured to the pole.

Technical Data

Dimensions (mm)	D	W	H
	201	179	384
Material	Powder Coated Stainless Steel		
Colour	Black		



V Bracket Mounting Bracket illustrating position of the AFN enclosure.



Front view of the Mounting Bracket.



Side view of the Mounting Bracket.

Technical Diagrams

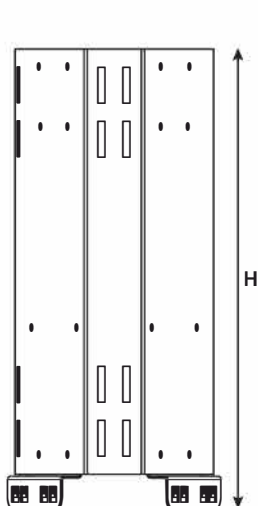

Front View

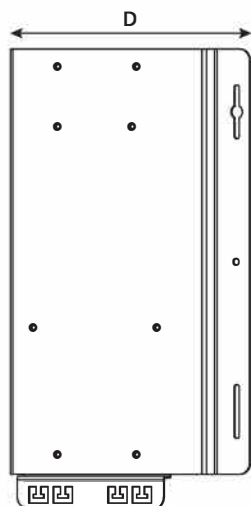

Side View

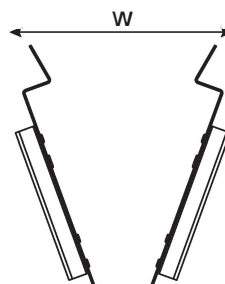

Top View

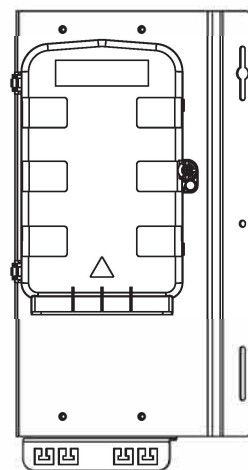

Side View shown with Fibre Facade Enclosure